

Eliminating High Voltage Capacitors with SBT3000 Smart AC Switch Controller

Abstract: The SBT3000, Power Line Smart AC Switch Controller solution was created in order to solve the overvoltage problem while eliminating additional costly and unreliable capacitors. The robust solid-state solution with its unique architecture automatically detects AC line over and under-voltage conditions while isolating the power line from the load until the AC input voltage is within its normal range. The solution provides continuous and reliable long-term voltage surge protection without the wear and unreliability issues of capacitors. Equipped with an output drive of 16V, the SBT3000 is an ideal solution for controlling any type of cost effective IGBT's. In addition, the device is housed in a convenient small form factor SOIC-8 package to suit a wide variety of applications.

In electronic devices, often the AC line input voltage is converted to DC and then fed into a capacitor for filtering. Figure 1 shows an example of a simplified input power circuit:

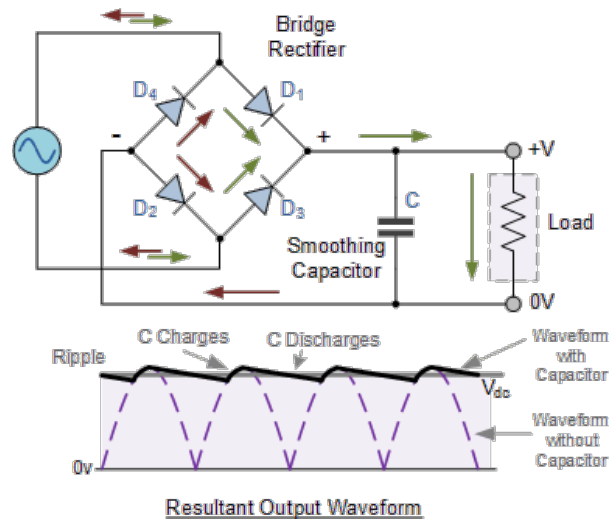

Figure 1: AC to DC Bridge Rectifier Circuit Diagram

The capacitor (C) shown in figure 1 charges up to the peak of the AC line voltage. For example, in many European countries this voltage is $230VAC \times 1.41 = 324VDC$. If the capacitor in figure 1 is rated at 450VDC, then the highest AC line voltage that could damage the capacitor is $450VDC \cdot .707 = 318VAC$. This means that without an over voltage protection (OVP) circuit, the input shall not go above 318VAC otherwise the capacitor will be permanently damaged.

The aforementioned capacitor above can be protected from short duration spikes by a varistor; however, a varistor does not protect the capacitor from longer duration of over voltage conditions. In addition, subsequent voltage spikes are even possible within an established and/or unreliable power grid. Aside from a temporary power surge, long term power surges are often created by the loss of the neutral connection on the input power. This can double the line voltage until the problem has been repaired which is on the next page.

In Europe, the homes are commonly powered by one of the outputs of a three phase “Y connected transformer as seen in Figure 2, each of the outputs of the transformer produces 230V from its output to the Neutral connection of the transformer.

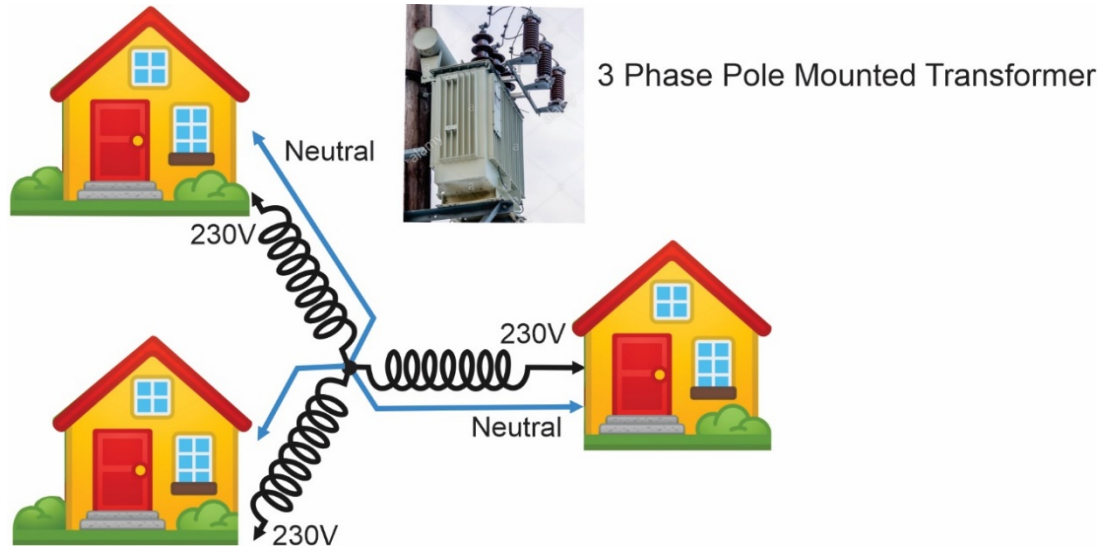

Figure 2: Typical European Home Power Connections

The three phase transformers that power homes are 230VAC between the phase to neutral wires and 400VAC between any two of the phase windings, as shown in Figure 3.

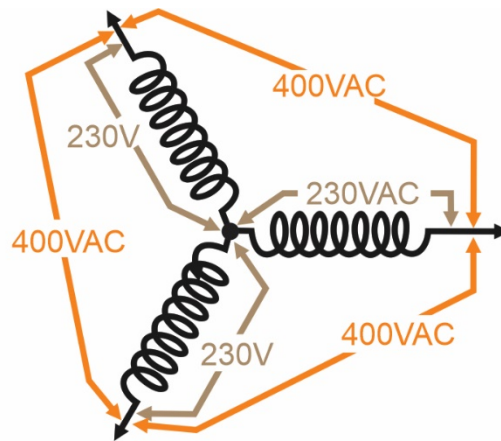

Figure 3: Secondary Side Voltages of a Three Phase Power Transformer

As shown in Figure 3, the three phase transformers that power homes are 230VAC between the phase to neutral wires and 400VAC between any two of the phase winding. When the neutral connection to the transformer is lost or burned out, it creates the problem shown in Figure 4.

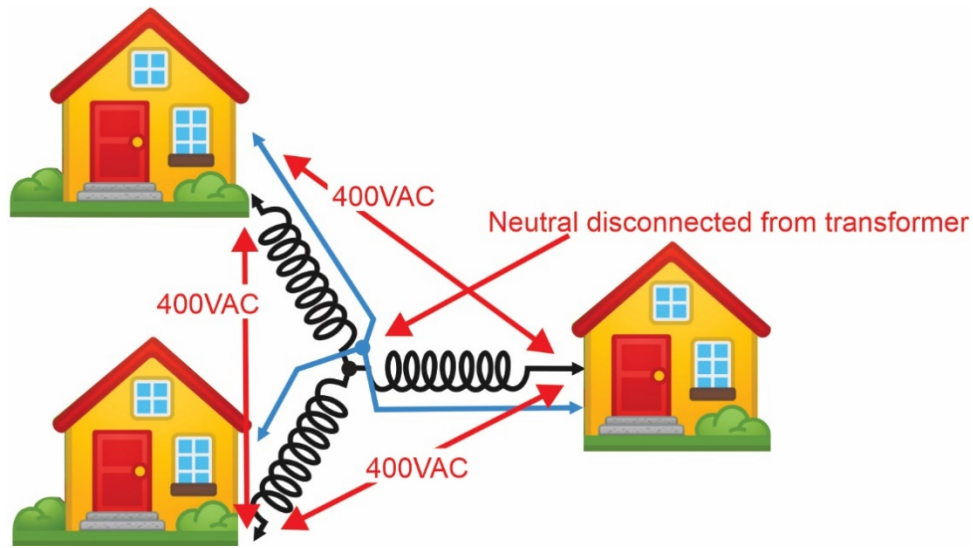

Figure 4: Voltages at Residential Houses if Neutral is Disconnected from Transformer

Furthermore, if the loads in all three houses are identical, which is unlikely, then there will be 230VAC in each house. If these loads are not balanced, there can be as much as 400V in a single house. Referring to Figure 1, there will be 564VDC across the capacitor and 400VAC at the input of the bridge rectifier which will cause a damage to the 450VDC rated capacitor (Figure 5).



Figure 5: Capacitor damage due to overvoltage

Increasing the voltage rating of a capacitor can potentially eliminate the issue described above; however, the problem with using a high voltage rating capacitor is that “normal” high value (>10uF) electrolytic capacitors are only sold, up to a 450V rating, and higher voltage capacitors are significantly more expensive (2x~3x) as they are sold as “specialty” types. Another solution would be putting capacitors in series to get a higher voltage rating but when capacitors are put in series, the effective value of the capacitors is cut in half which requires two more capacitors in series to get the same capacitance.

For example, using four capacitors increases the size and solution cost of the product as shown below. It also lowers the product reliability as there is a higher probability for one these capacitors failing.

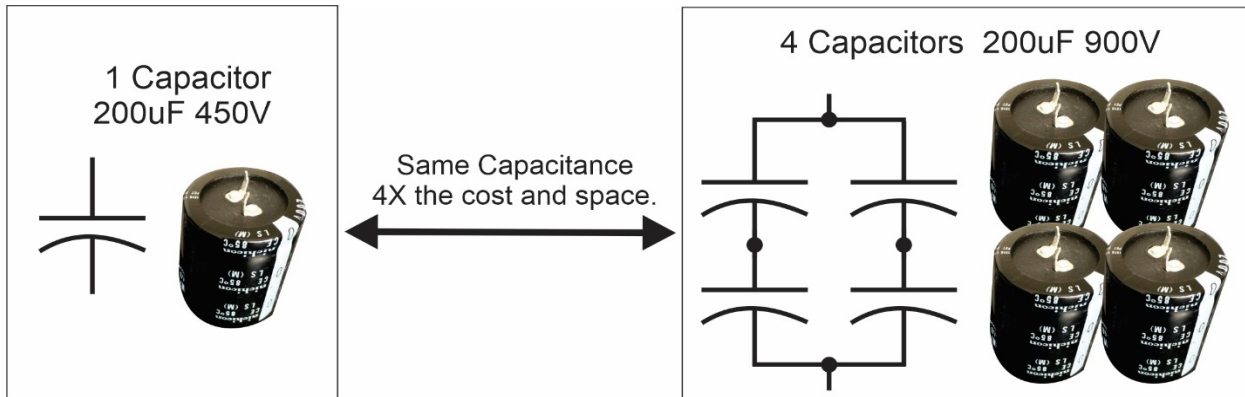

In conclusion, SBT3000 offers a superior protection and powerful solid-state chip alternative to an unreliable, high wear-out capacitor-based solutions. The device protects sensitive electronics from both over and under-voltage spikes by automatically disconnecting the load from the source during unstable power line conditions which ultimately enhance the reliability and potentially boost end-product lifespan of an end-equipment. For more technical information including product brief, datasheet application note, product samples, and evaluation demo board please email to:

info@siliconbrite.com



Copyrights, Trademarks and Patents

SiliconBrite, SBT, and SiliconBrite logo are trademarks of SiliconBrite Technologies Inc.

SiliconBrite Technologies has patents and pending global patent applications that protect its products.

SILICONBRITE TECHNOLOGIES MAKES NO WARRANTY, REPRESENTATION OR GUARANTEE, EXPRESS OR IMPLIED, REGARDING THE SUITABILITY OF ITS PRODUCTS FOR ANY PARTICULAR PURPOSE, NOR THAT THE USE OF ITS PRODUCTS WILL NOT INFRINGE ITS INTELLECTUAL PROPERTY RIGHTS OR THE RIGHTS OF THIRD PARTIES WITH RESPECT TO ANY PARTICULAR USE OR APPLICATION AND SPECIFICALLY DISCLAIMS ANY AND ALL LIABILITY ARISING OUT OF ANY SUCH USE OR APPLICATION, INCLUDING BUT NOT LIMITED TO, CONSEQUENTIAL OR INCIDENTAL DAMAGES.

SiliconBrite Technologies products are not designed, intended, or authorized for use as components in systems intended for surgical implant into the body, or other applications intended to support or sustain life, or for any other application in which the failure of the SiliconBrite product could create a situation where personal injury or death may occur.

SiliconBrite Technologies reserves the right to make changes to or discontinue any product or service described herein without notice.